

VEHICLE TYPE

180-617-620-622 BMC PRO / 200.26-180 FATİH BMC /
2520 FORD CARGO / AS 950 CHRYSLER180.12-210-
220CD-320 MIDLUM RENAULT / FODEN 2000 /
ERF E6.18 / 1415-1718 FORD 8.163-8.224-18.224
MAN / FEDON ATKINSON E6.11 / STEYR 14S22 P37 4X2

TRANSMISSION TYPE

EATON FS / FSO / H / V 4106(6,08-9,03-7,54)
- 5206(6,08-9,03) A / B / H / DT / OD
3105 - 4105 - 5109(9,05-6,84) - 5209 - 5206
-6309 - FS 6406 AE

Kozmaksan Eaton-Fuller Power Take OFFs designed for Eaton-Fuller series main transmissions. Kozmaksan EAT-FUL PTOs has Single&Double output models, Rear&Side Mounting type options and available for UNI&ISO mounting housing or suitable for flange connections.

Applications;

- Garbage Truck
- Crane Truck
- Dump Truck

PNEUMATIC

REAR MOUNTING

EAT.3.4106

Product Code

Transmission
TypeEATON FS / FSO / H / V 4106 (6,08-9,03-7,54) - 5206(6,08-9,03)
A / B / H - 3105 - 4105 - 5109(9,05-6,84) - 5209 - 5206 - 6309

01

08.02.2019

2/4

Rev. Date

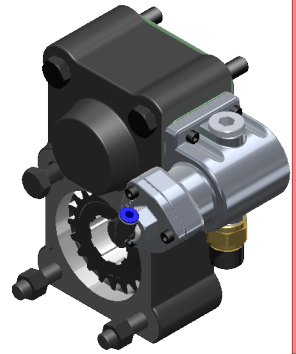
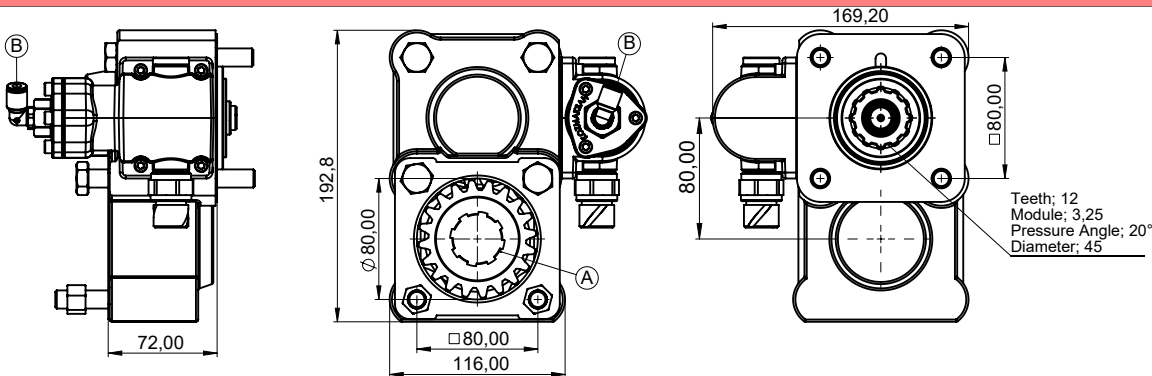
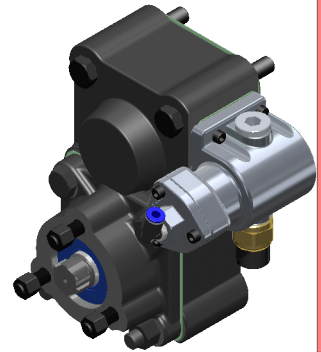
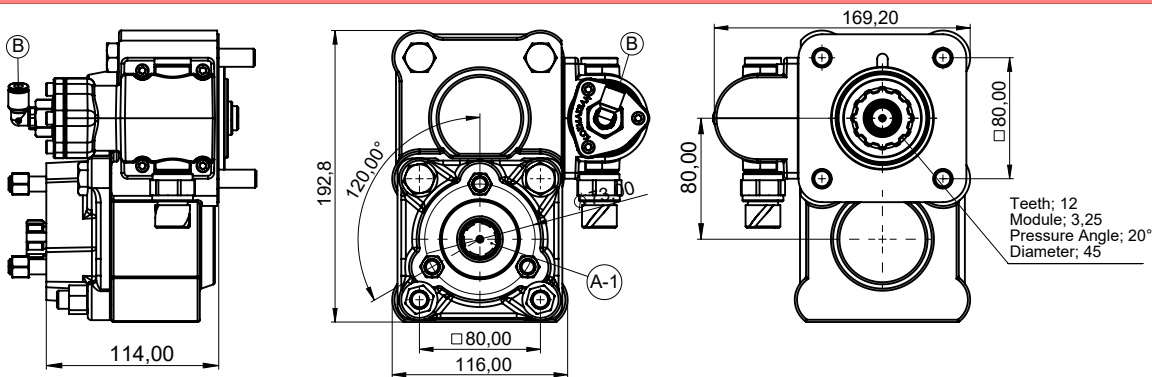
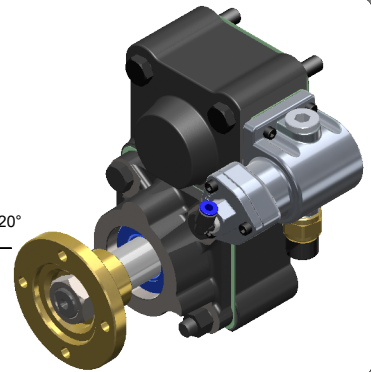
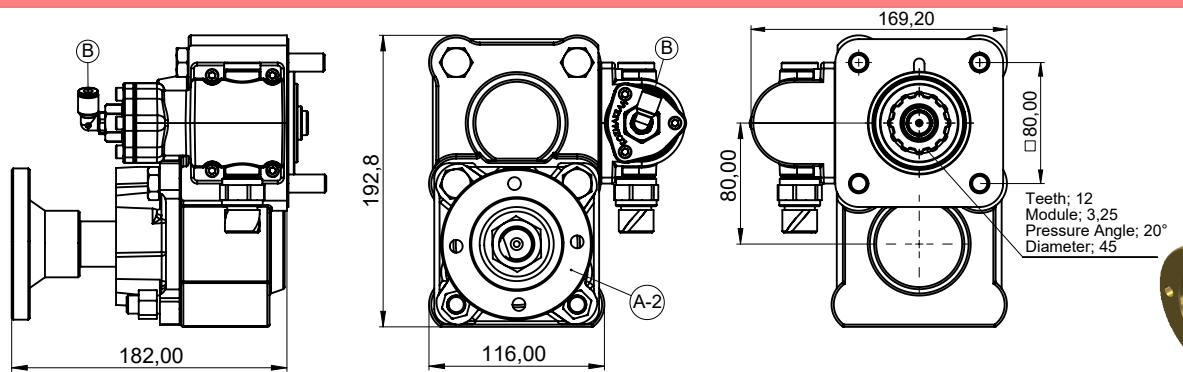
ISO OUTPUT**UNI OUTPUT****FLANGE OUTPUT****A** Output - DIN 5462 / 32x36x8 / ISO 14 4 Bolts**B** Air Inlet**A-1** Output - DIN 5463 / 6x21x25 / UNI 3 Bolts**A-2** Output - ISO 7647-7646 Standard Flange

	ISO Output	UNI Output	FLANGE Output
Power(kW)@1000 RPM	34,5	23	34,5
Max. Torque (Nm)	330	220	330
Weight (Kg)	8,5	11,5	14
Ratio	1/1.2		
Mounting Type	Rear Mounting		
Sense of Rotation	CCW		

- Kozmaksan has all rights to change information in this catalogue without announcing it. This document is representing general information. It is not a contract.
- All information belongs to only PTO/Split Shaft. Do not use PTO/Split Shaft, if it is not suitable for your engine and main transmission.
- Pumps, shafts and other parts should not be longer or heavier than approved distance and weight by the manufacturer of main transmission and engine.

KozmaksanPTO



kozmaksanpto



kozmaksan-hydraulics-pt



1.OSB. Erkunt Cad. No: 6 Sincan / ANKARA
Tel.+90 312 267 39 71-Fax +90 312 267 38 72
order@kozmaksan.com.tr
www.kozmaksan.com.tr

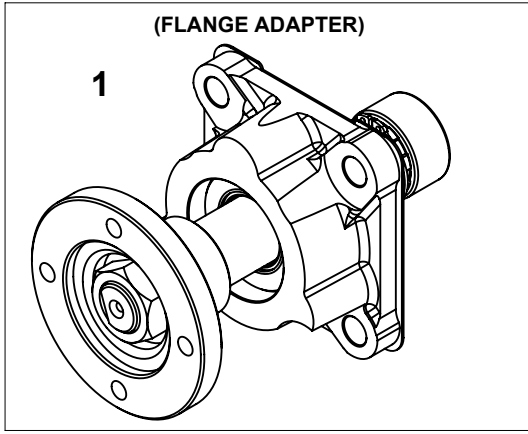

EAT.3.4106

Product Code

01

08.02.2019

3/4

Rev. Date

1.4

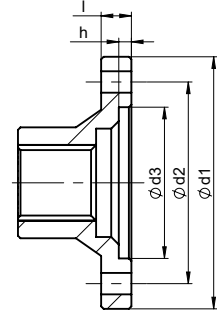
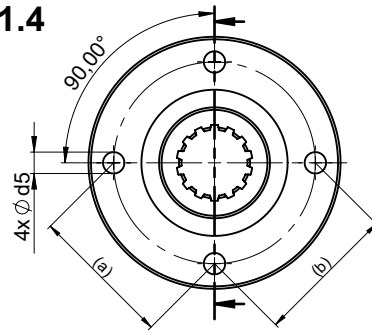

1.5

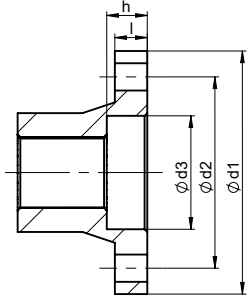
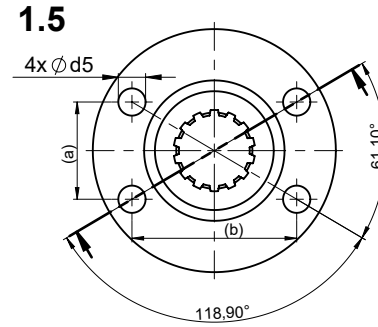

1.1

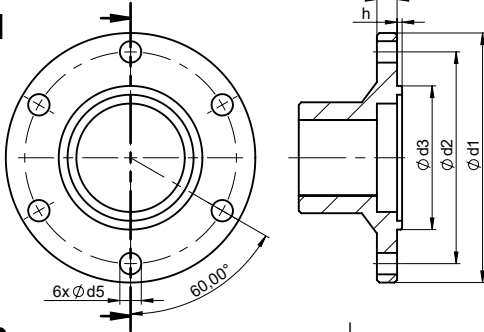

1.2

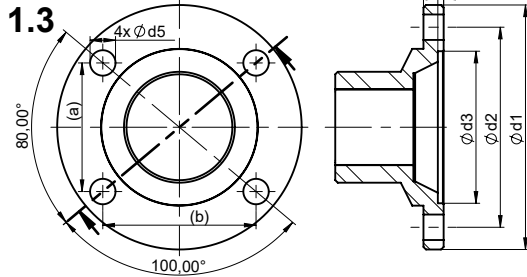

1.3

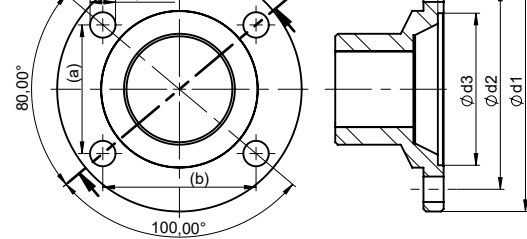

	Ød1	Ød2	Ød3	Ød5	l	h	delik sayısı	(a) x (b)
1.1	100	84	57	8,1	8	2,3	6	-
1.2	97	79,37	60,32	10,1	8	2,3	4	51 x 60,8
1.3	87	69,85	57,10	8,1	2	2	4	45 x 53,5
1.4	100	80	60	8,5	12	5	4	56,5 x 56,5
1.5	90	70,83	42	10,1	12	15	4	36 x 61

All dimensions are mm.

No	Code	Description			
1	KIT.55.03.UF	Flange Adapter			
1.1	C06-076	ISO 7646-100x6x8			
1.2	C06-045	ISO 7647-SAE 1300x4x10			
1.3	C06-082	ISO 7647 - SAE 1100x4x8			
1.4	C06-194	Ø100 Flange			
1.5	C06-192	Ø90 Flange			

- Kozmaksan has all rights to change information in this catalogue without announcing it. This document is representing general information. It is not a contract.
 - All information belongs to only PTO/Split Shaft. Do not use PTO/Split Shaft, if it is not suitable for your engine and main transmission.
 - Pumps, shafts and other parts should not be longer or heavier than approved distance and weight by the manufacturer of main transmission and engine.

KozmaksanPTO



kozmaksanpto



kozmaksan-hydraulics-pt



1.OSB. Erkunt Cad. No: 6 Sincan / ANKARA
 Tel.+90 312 267 39 71-Fax +90 312 267 38 72
 order@kozmaksan.com.tr
 www.kozmaksan.com.tr

(UNI Output Adapter)

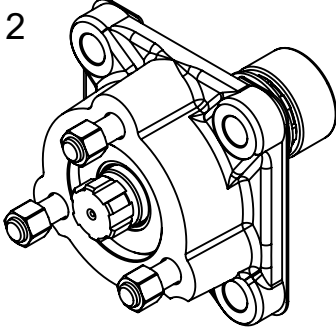

(ISO Extension Kit)

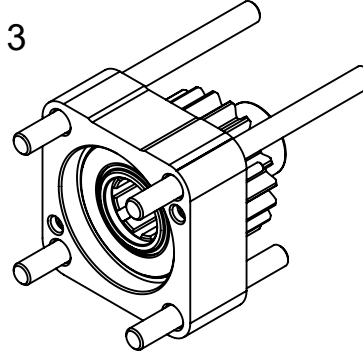

4

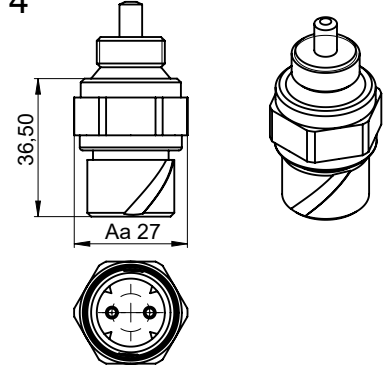

No	Code	Description			
2	KIT.52.02.KF	UNI Adapter			
3	KIT.1.ISO	ISO Extension Kit			
4	T12-001	Engage/Disengage Sensor			

- Kozmaksan has all rights to change information in this catalogue without announcing it. This document is representing general information. It is not a contract.
 - All information belongs to only PTO/Split Shaft. Do not use PTO/Split Shaft, if it is not suitable for your engine and main transmission.
 - Pumps, shafts and other parts should not be longer or heavier than approved distance and weight by the manufacturer of main transmission and engine.

KozmaksanPTO



kozmaksanpto



kozmaksan-hydraulics-pt

